

A Protection Class of its Own

Combined IDMTL Overcurrent & Earth Fault Relay • REA200n

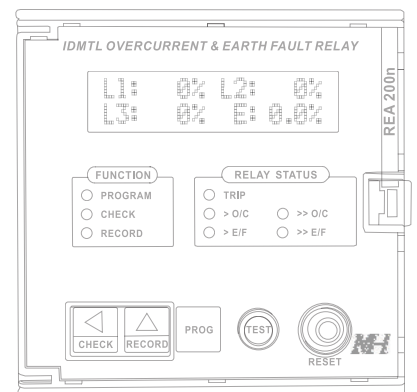
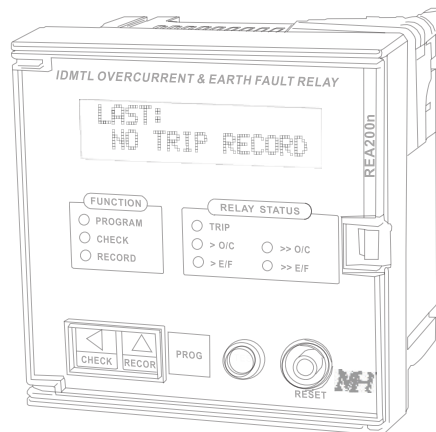

REA 200n

- ANSI 86 LOCKOUT RELAY
- ANSI 51N/51G IDMTL EARTH FAULT RELAY
- ANSI 51 IDMTL OVERCURRENT RELAY
- ANSI 50N/50G DTL EARTH FAULT RELAY
- ANSI 50 DTL OVERCURRENT RELAY

MH Protection Relays

MH Represents a legacy of design and development, specializing in power management and power quality solutions and its core expertise, electrical protection relays. The MH Protection Relays has its heritage dated since 1981 where, designed by Mun Hean and OEM by Kasuga of Japan, developed a range of electronic relays that dominated the market for decades. The range of relays were marketed under the brand name "Kasuga-MH".

Today, with its own R&D wing, Mun Hean Technology Pte Ltd, MH continues this tradition. Anchored on the exclusive MTB fault indication system, we proudly bring to you this state-of-the-art protection relay series that is truly, A Protection Class of its Own.

Features

- Microprocessor-based with highest accuracy
- Mechanical Trip Button (MTB) fault indication system
- No requirement for auxiliary power supply for fault indication
- Safeguard against automatic reset before fault rectification
- Curve selection in accordance with ANSI, IAC, IEC, 1.3/10, Hong Kong Utilities Curve
 - Normally Inverse (NI)
 - Very Inverse (VI)
 - Extremely Inverse (EI)
 - Short Time Inverse (STI)
 - Moderate Inverse (MI)
- Trip value recording (4-memory)
- Date and time stamping for tripping
- Integrated surge arrester against transient overvoltages
- High set mode is incorporated for instantaneous protection
- Tamper-proof design for settings protection
- Serial interface RS485 for Modbus RTU communication (optional)
- Type tested* for EMC compliance in acc. with IEC 61000
- High immunity to electrical interference (tested to 2.5GHz)
- Type tested in acc. with IEC 60255*
- Comply to ANSI 86, 51N/51G, 51, 50N/50G, 50

* Type test report issued by independent testing laboratory is available upon request

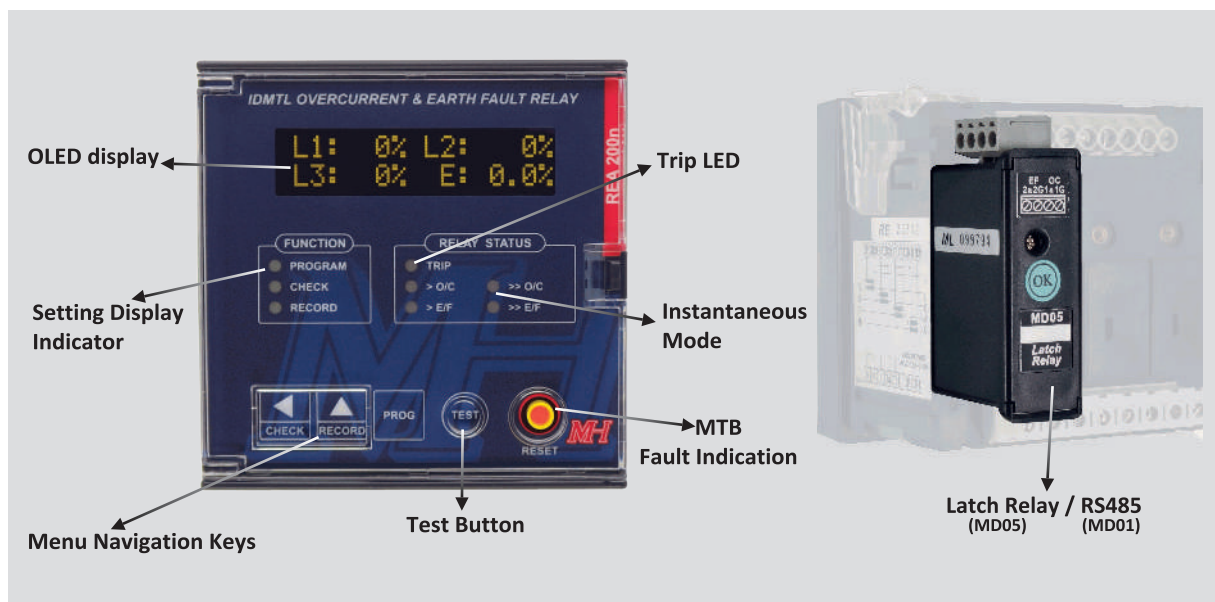

Technical Data

Characteristics		
Power supply		AC / DC 85-265V (other voltages available on request)
Operating frequency		50 / 60Hz
Power consumption		≤ 6VA
Rated Input Current		5A (1A available upon request)
Earth fault setting		2.0 - 50.0% in step of 0.1%
Overcurrent setting		20 - 200% in step of 1%
Time multiplier setting		0.03 - 2.00 in step of 0.01 (IEC, 1.3/10)
		0.3 - 20.0 in step of 0.1 (ANSI, IAC)
Definite time delay setting (DTL)		0.03 - 2.00 sec in step of 0.01 sec
Instantaneous Mode (High-set)		2.0 - 10.0 times setting current in step on 0.1
Working temperature range		- 10°C to 55°C
Storage temperature range		- 20°C to 65°C
Relative humidity (IEC 60068-2-30)		< 93%, non-condensing
Degree of protection		IP31 (front), IP20 (back) Optional IP65 front cover
Overcurrent withstandability		10 * I rated (for 1 sec)
Output	Relay Output	1 x C/O (Changeover), 1 x N/O (Normally Open)
	Contact Rating	2A at 250VAC
Optional interface		RS485 Modbus RTU
LED status indication		Normal operation, fault current detected
Safety feature		Mechanical Trip Button (MTB) complying with ANSI 86
Housing material		ABS resin complying with UL94VO
Net weight		Approximately 390g
Dimensions		96mm (width) x 96mm (height) x 86mm (depth)
Panel cut-out		92mm (width) x 92mm (height)

Compliance with standards		
MTB Fault Indication System		ANSI 86 Lockout Relay
Product Safety Requirements		IEC 60255-27
Electromagnetic Compatibility		CISPR11/22 (IEC 60255-26)
		IEC 61000-4-2 (IEC 60255-26)
		IEC 61000-4-3 (IEC 60255-26)
		IEC 61000-4-4 (IEC 60255-26)
		IEC 61000-4-5 (IEC 60255-26)
		IEC 61000-4-6 (IEC 60255-26)
		IEC 61000-4-8 (IEC 60255-26)
		IEC 61000-4-11 (IEC 60255-26)
Vibration, Shock and Bump		IEC 60255-21-1
		IEC 60255-21-2
Dry Heat, Damp Heat, Steady State,		IEC 60068-2-2 (IEC 60255-1)
Cyclic Temperature with Humidity		IEC 60068-2-78 (IEC 60255-1)
		IEC 60068-2-30 (IEC 60255-1)
Safety		CE Marking

Characteristics Curve

Time Current Characteristics in accordance with IEC 60255

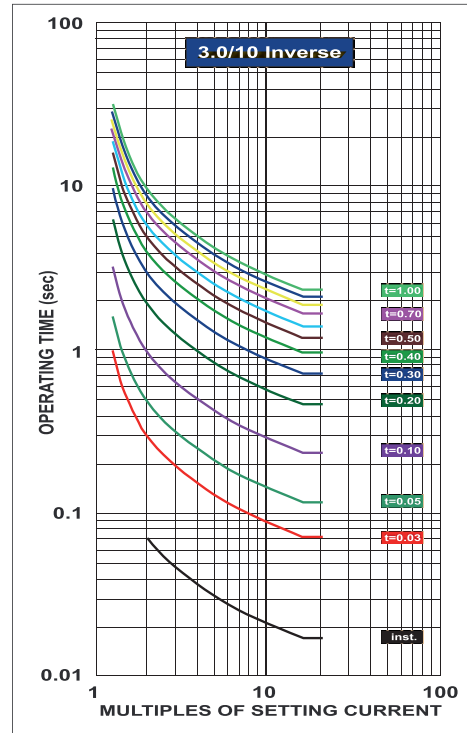
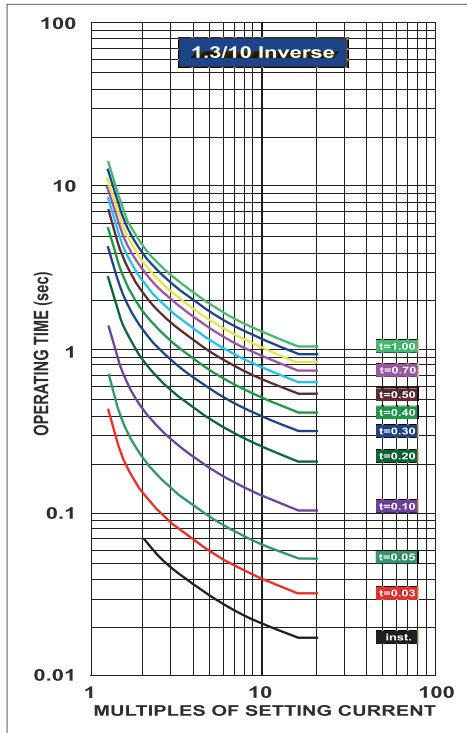

Connection Diagram

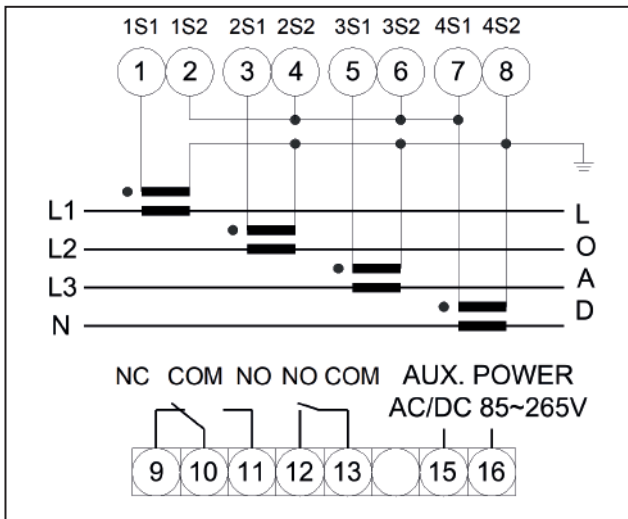

About MTB Fault Indication System

MTB, or Mechanical Trip Button is a fault indication system incorporated in advanced protection relaying for electrical power networks. The MTB does not require auxiliary supply to provide a fault indication. The MTB is designed to prevent power circuits from re-energising before a fault is completely rectified. This is an essential safety feature which protection relays using electrical latching mechanisms are not able to provide.

Authorized Dealer:

OPERATION MANUAL

